

Signet 4150 Turbidimeter



Features

- Simple and easy one-unit installation with built-in pressure regulator
- EPA compliant per U.S. EPA 180.1
- Programmable 4-20 mA output
- Two alarm relays
- Bright backlit display
- Convenient cuvette holder
- Easy access for wiring and maintenance
- Ultrasonic cleaning option insures long and steady on-line measurement
- Inexpensive standards allow for multiple system calibration

Description

The Signet 4150 Turbidimeter system provides accurate and reliable EPA-compliant water quality monitoring for municipal and industrial applications.

The 4150 measures turbidity via a 90 degree light which reflects particles as they flow through the small volume, low flow glass cuvette. Air bubbles are eliminated in the cuvette by adjusting the backpressure valve on the outlet tube. The cuvette is located in a watertight dark chamber for continuously accurate on-line measurement. A replaceable desiccant pack provides stable environment to ensure reliable measurements.

Simple and fast calibration can be accomplished in under five minutes by placing the glass cuvette from the measuring chamber into the cuvette

holder, while the inlet and outlet tubing is still connected. The inexpensive calibration standard allows for dry and multiple system calibrations without mixing chemicals. After calibration, the unit is up and running with a simple insertion of the glass cuvette into the measuring chamber.

Additional features of the 4150 include a message indicator when the desiccant needs replacing and auto/ultrasonic cleaning of the glass cuvette for reduced maintenance.

The 4150 is available in two measuring ranges. The 0 to 100 NTU version is for low range applications such as drinking water. The 0 to 1000 NTU range can be used for various applications including raw water and wastewater.

Applications

- Membrane Filtration
- Monitoring Filter Performance
- Raw or Filtered Water
- Municipal Water Distribution
- Wastewater Effluent
- Aquatic Life Support

Systems Overview

4150 Turbidimeter	
<p>1 - Mounting Bracket 2 - Power Supply and Wiring Terminals 3 - Operator Interface with Display 4 - Desiccant Access 5 - Glass Cuvette (Ultrasonic option)</p> <p>6 - Backpressure Valve 7 - Cuvette Holder 8 - Shutoff Clamp 9 - Tubing and Fittings 10 - Measuring Cell Chamber</p>	



Dimensions

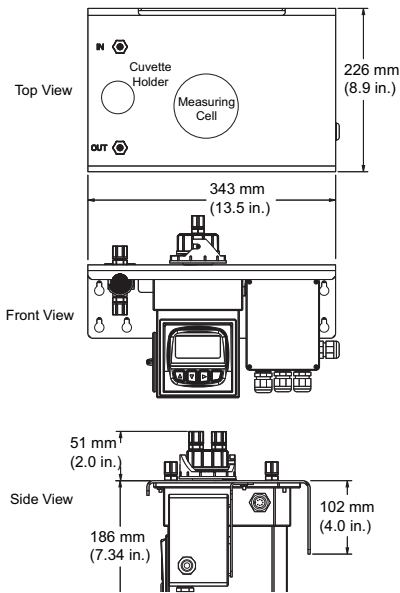

4150-0004

Cuvette with ultrasonic transducer

4150-0007

Glass cuvette non-ultrasonic (not shown)

Specifications

General

Flow Rate: 0.1 L/min to 1 L/min
(0.026 GPM to 0.26 GPM)

Measurement Range:
0 to 100.0 NTU or 0 to 1000.0 NTU

Accuracy:

- ±2% of reading or ±0.02 NTU below 40 NTU whichever is greater
- ±5% of reading above 40 NTU

Mounting

- Horizontal plane, integral mounting bracket (with standard hole pattern)
- Use 4.75 mm (3/16") ID, 8 mm (5/16") OD flexible tubing for the water supply/outlet (customer supplied)

Resolution

0.0001 NTU (below 10 NTU)

Display

Two-Line LCD w/backlight

Alarm Relays

120-240 VAC, 2A Form C Relay

Customer Selectable

Active 4-20 mA, 600 Ω
RS 485

Wetted Materials

- Tubing: Nylon
- Measuring cuvette: Borosilicate Glass
- Glass washer seal: Silicon
- Pressure regulator: Polypropylene, 316 Stainless Steel, Delrin® by Dupont™
- Inlet tube: 316 Stainless Steel

Maximum Pressure

- Integral pressure regulator rated 1380 kPa (200 PSI)

Operating Temperature

- 1°C to 50°C (34°F to 122°F)

Power Supply

100 – 240 VAC,
47 – 63 Hz, 80 VA

Insulation Rating

- Double Insulated
- Pollution Degree 2
- Overvoltage Category II

Altitude

2000 meters (6,561 feet) maximum

Relative Humidity

Maximum 95% RH non-condensing

Enclosure Rating

IP 66 /NEMA 4X

Environmental Conditions

For indoor use

Shipping Weight

2.5 kg (5.5 lbs.)

Regulatory Compliance and Certifications:

- CE
- Nephelometric 90 degree white light version compliant to U.S. EPA 180.1
- ETL Certified:
CSA 22.2 No. 1010-1-92

Ordering Information

System Part Number		
3-4150	Measurement range and self cleaning options	
↓	-1	White Light, 0 to 1000 NTU, no self cleaning
	-3	White Light, 0 to 100 NTU, ultrasonic cleaning
	-5	White Light, 0 to 1000 NTU, ultrasonic cleaning
3-4150	-3	Example Part Number

Mfr. Part No.	Code
3-4150-1	159 001 596
3-4150-3	159 001 598
3-4150-5	159 001 600

Accessories and Replacement Parts

Mfr. Part No.	Code	Description
3822-4001	159 001 585	Calibration Kit, Turbidity, 100, 10 & 0.02 NTU
3822-4003	159 001 586	Calibration Kit, Turbidity, 1000, 10 & 0.02 NTU
3-4150.380	159 001 588	Replacement Desiccant
3822-4002	159 001 591	Formazin Stock Kit
3822-4000	159 001 592	Formazin Stock Solution, 4000 NTU, 500 ml
4150-0007	159 001 602	Replacement Cuvette Set (3 glass cuvettes)
4150-0004	159 001 589	Replacement Cuvette with Ultrasonic Transducer

Georg Fischer Signet LLC

3401 Aerojet Avenue, El Monte, CA 91731-2882 U.S.A. • Tel. (626) 571-2770 • Fax (626) 573-2057 • www.gfsignet.com • e-mail: signet.ps@georgfischer.com
Specifications subject to change without notice. All rights reserved. All corporate names and trademarks stated herein are the property of their respective companies.